



SMPR-1 v1.XX

Current - Voltage - Power
Measurement & Protection Relay



Summarize Measurement
and Protection Relay

DESCRIPTION

The SMPR-1 has been designed to measure the line and the ground RMS currents and supply RMS voltages under normal conditions or under disturbances. This information is internally processed by the microprocessor, to take the protection actions defined by the user under ANSI, IAC or IEC standards. The operational conditions of the breaker or disconnector are also signalized

APPLICATIONS

- Primary and backup protections for power plants, utility and industrial distribution systems.
- Protection of transformers, overhead lines, cables and generators.

PROTECTION AND FUNCTIONALITY

- **(27)** Undervoltage.
- **(32)** Directional power.
- **(37)** Undercurrent.
- **(46)** Negative sequence current.
- **(47)** Phase-sequence voltage
- **(50)** Instantaneous phase overcurrent.
- **(50N/50G)** Instantaneous ground overcurrent.
- Overload alarm pickup level.
- **(51)** Inverse time phase overcurrent
- **(51N/51G)** inverse time ground overcurrent,
- ANSI, IAC or IEC/BS142 curves included:
 - Moderately inverse
 - Normal inverse
 - Very inverse
 - Extremely inverse
 - Definite time
- **(55)** Power factor.
- **(59)** Overvoltage.
- **(68)** Blocking output.
- **(81)** Underfrequency and Overfrequency.
- **(86)** Lockout.
- Accumulated KA per phase on breaker interruption.

COMMUNICATION

- Remote communication using a PC or PLC by RS485 or RS232
- Remote programming of the setpoints.
- Remote breaker opening or closing.

FEATURES

- CT primary ratio selectable in 5 A steps (5 to 5000 A).
- Touchpad programming.
- 1 trip relay.
- 3 auxiliary relays that can be associated to the various functions.
- Power loss or internal fault control relay.
- 3 programmable Digital inputs and 1 Digital input for breaker status.
- Breaker operation failure alarm on trip command.

SIGNALLING AND DIGITAL MEASUREMENT

- LED and LCD display indication.
- Last trip cause and relative data.
- Indication and storage of fault condition and their values.
- Indication of the breaker status (open, close, earthed)
- RMS line and ground currents.
- RMS line or phase voltages.
- Active power (kW), reactive power (kvar) and apparent power (kVA).
- Active energy (MWh) and reactive energy (Mvarh).
- Power factor and system frequency.
- Positive and negative real power (kW) and reactive power (kvar).
- Demand and maximum demand: current in each phase (A), real power (kW), reactive power (kvar).

APPLICABILITY

<i>Systems:</i>	Wye or delta three-phase
<i>Frequency</i>	50 and 60 Hz
<i>Current:</i>	5000 A maximum
<i>Voltage:</i>	69 kV maximum



SPECIFICATIONS

SUPPLY VOLTAGE 24÷310 Vdc, -15%,+10% 24÷240 Vac, -15%, +10%	MAX POWER CONSUMPTION 7 W or 12 VA (peak)
TEMPERATURE RANGE Operational: 0 °C ÷ 50 °C Storage: -20 °C ÷ 70 °C	RELATIVE HUMIDITY Max. 90% (non condensing)
DIELECTRIC WITHSTAND VOLTAGE 2 kV 60 s	BURN IN 48 hours at 50°C
CONSTRUCTION In compliance with VDE, UL, CEI standards	OUTPUT CONTACT <i>Load:</i> resistive (p.f. = 1) inductive (p.f. = 0,4; L/R = 7ms) <i>Rated load:</i> 250 Vac, 8 A or 30 Vdc, 8 A with p.f. =1 250 Vac, 5 A or 30 Vdc, 5 A with p.f. =0,4 <i>Max. operating Voltage:</i> 250 Vac, 125 Vdc <i>Max. operating Current:</i> 8 A
AMBIENT FEATURES The relay must be installed in a room with the following features: - indoor, - dry, not dusty and not corrosive atmosphere.	
COMMUNICATIONS <i>Type:</i> One RS232 port + two 2-wire RS485 ports, Full duplex, 1200÷19200 baud <i>Protocol:</i> Modbus RTU <i>Functions:</i> Reading/Writing of setpoints Reading of actual values Executing of commands	LED INDICATORS <i>Relay status:</i> Trip, AUX1, AUX2, AUX3, Out of Service <i>System status:</i> Circuit breaker closed, Circuit breaker open, Circuit breaker earthed, lockout, *auto-reclose enable, *auto-reclose in progress. (*not used in this version) <i>Display (LCD):</i> 16 x 2 digits <i>Display accuracy:</i> Load current: ±1% @ 100% CT System voltage: ±1% @ 100% VT
DIGITAL INPUT <i>Type:</i> Dry contacts <i>Output:</i> 24 Vdc, 10 mA (stabilized)	TERMINAL BLOCK Fixed, for cables with section: 4-mm ² (12 AWG)
FRAME Auto-extinguishing ABS with frontal in polycarbonate (IP54)	ASSEMBLY The relay has to be jointed to the structure fixing it with the help of the stirrup with screws.
DIMENSION 144 x 144 x 141 mm (→ Fig. 2.1 – SMPR overall dimensions)	FRONT PANEL CUTOUT 137 x 137 mm
WEIGHT 1.5 kg	
PHASE AND GROUND CT INPUTS <i>Source CT:</i> CT: 5÷5000 A. <i>Rated CT secondary:</i> CT: 1 A or 5 A (specify with order). <i>Sampling:</i> True RMS with 16 samples per cycle. <i>CT burden:</i> 0.25 VA per phase at rated secondary current. <i>Continuous:</i> 10 A <i>Current withstand capac.:</i> 1 second @100A	VOLTAGE INPUT <i>VT input:</i> <u>Secondary:</u> 55÷254 Vac, Steps: 1 V; <u>Primary (Un):</u> 0.10÷69 kV, Steps: 0.01/0.1 kV. <i>VT burden:</i> 1 VA max. <i>Max. Continuous:</i> 254 Vac phase-neutral.
CURRENT UNBALANCE <i>Pickup Δf:</i> 1÷99%, Steps: 1% <i>Delay:</i> 0.05÷600 s, Steps: 0.01/0,1/1 s <i>Current accuracy:</i> ±3% of set current per I>6%CT <i>Time accuracy:</i> ±3% of trip time or ± 40ms (whichever is greater)	OVERCURRENT CURVES Selection of phase and ground curves according to ANSI, IAC or IEC. <ul style="list-style-type: none"> • Moderately inverse • Normally inverse • Extremely inverse • Definite time The curves are valid up to 18 times the CT rated current.
	(81) UNDER/OVERFREQUENCY PROTECTION <i>Pickup Δf:</i> 0.05÷9.99 Hz, Steps: 0.01 Hz <i>Dropout Δf:</i> 0.01÷5 Hz, Steps: 0.01 Hz <i>Delay:</i> 0.1÷600 s, Steps: 0.1 ms <i>Accuracy:</i> ±0.1 Hz per Δf < 8Hz across A-N or A-B voltage <i>Measured:</i> ±3% or ±50 ms (whichever is greater) per delay time > 0.5 s

<p>(37) PHASE UNDERCURRENT <i>Pickup:</i> 2÷100%CT, Steps: 1% <i>Delay:</i> 0.05÷600 s, Steps: 0.01/0.1/1 s <i>Current accuracy:</i> ±3% of set undercurrent per I>6%CT <i>Time accuracy:</i> ±3% of trip time or ± 50ms (whichever is greater).</p>	<p>(46) NEGATIVE SEQUENCE TIME OVERCURRENT <i>Pickup level:</i> 4÷300% CT, Steps: 1% <i>Time multiplier:</i> 0.1÷20.0; Steps: 0.1 <i>Dropout level:</i> 97% Ipk <i>Accuracy:</i> ± 3% of the setting. <i>Def. Time accuracy:</i> included in ±3% or in ±60 ms (whichever is greater), per I >150% Ipk.</p>
<p>(50) PHASE INSTANTANEOUS OVERCURRENT <i>Pickup level:</i> 4÷1800% of CT, Steps: 10% <i>Definite time:</i> 0÷2000 ms, Steps: 10ms <i>Current accuracy:</i> ± 3% of the setting @ I<3xCT ± 6% of the setting @ I>3xCT <i>Time accuracy:</i> ± 55 ms max. per I > 150% Ipk <i>Saturation:</i> 18 times the CT rated current.</p>	<p>(50G/50N) GROUND INSTANTANEOUS OVERCURRENT <i>Pickup level:</i> 4÷1800% of CT, Steps: 10% <i>Definite time:</i> 0÷2000 ms, Steps: 10ms <i>Current accuracy:</i> ± 3% of the setting @ I<3xCT ± 6% of the setting @ I>3xCT <i>Time accuracy:</i> ± 55 ms max. per I > 150% Ipk <i>Saturation:</i> 18 times the CT rated current.</p>
<p>(51) PHASE TIME OVERCURRENT <i>Pickup level:</i> 4÷300% CT, Steps: 1% <i>Time multiplier:</i> 0.1÷20.0; Steps: 0.1 <i>Definite time:</i> 0.05÷600 s, Steps: 0.01/0.1/1s <i>Dropout level:</i> 97% Ipk <i>Accuracy:</i> ± 3% of the setting. <i>Def. Time accuracy:</i> included in ±3% or in ±45 ms (whichever is greater), per I >150% Ipk</p>	<p>(51G/51N) GROUND TIME OVERCURRENT <i>Pickup level:</i> 4÷300% CT, Steps: 1% <i>Time multiplier:</i> 0.1÷20.0; Steps: 0.1 <i>Definite time:</i> 0.05÷600 s, Steps: 0.01/0.1/1s <i>Dropout level:</i> 97% Ipk <i>Accuracy:</i> ± 3% of the setting. <i>Def. Time accuracy:</i> included in ±3% or in ±45 ms (whichever is greater), per I >150% Ipk.</p>
<p>(47) PHASE-SEQUENCE VOLTAGE <i>Normal condition:</i> Sequence A-B-C = Sequenced <i>Fault condition:</i> Sequence A-C-B = Not Sequenced <i>Indef. condition:</i> Sequence NONE = the relay can not detect the voltage sequence <i>Delay:</i> 0.05÷600 s, Steps: 0.01/0.1/1s</p>	<p>(55) POWER FACTOR PROTECTION Alarm and trip power factor <i>Pickup:</i> 0.05÷1.00 Lag, Steps: 0.01 0.05÷1.00 Lead, Steps: 0.01 <i>Delay:</i> 0.5÷600 s, Steps: 0.5/1s <i>Accuracy:</i> ±0.015 per V<150V & PF>0.5</p>
<p>(59) OVERVOLTAGE PROTECTION <i>Pickup level :</i> 1% to 150% VT; Steps: 1% <i>Dropout level:</i> 1% to 150% VT; Steps: 1% <i>Delay:</i> 0.0 to 600.0 s; Steps: 0.01/0.1/1 s <i>Pickup accuracy:</i> ±0,5% of full scale per Vpk<200V ±1% of full scale per Vpk>200V <i>Reset accuracy:</i> ±0,5% of full scale per Vpk<200V ±1% of full scale per Vpk>200V <i>Time accuracy:</i> ±3% of trip time or ±30ms (whichever is greater) at 0ms time delay (no intentional delay) 70ms max per V>1.2Vpk <i>Operation Phases:</i> Any one / Any two / All three / Homopolar</p>	<p>(27) UNDERVOLTAGE PROTECTION <i>Pickup level :</i> 15% to 100% VT; Steps: 1% <i>Dropout level:</i> 15% to 100% VT; Steps: 1% <i>Curve:</i> Inverse, Definite <i>Delay:</i> 0.0 to 600.0 s; Steps: 0.01/0.1/1 s <i>Pickup accuracy:</i> ±1% of full scale (15 ≤ V ≤ 60) ±0,5% of full scale (60 < V ≤ 254) <i>Reset accuracy:</i> ±1% of full scale (15 ≤ V ≤ 254) <i>Time accuracy:</i> ±3% of trip time or ±40ms (whichever is greater) at 0ms time delay (no intentional delay) 90 ms max @ V < 80% Vpk <i>Operation Phases:</i> Any one / Any two / All three <i>Minimum oper. level:</i> 0% to 100% VT; Steps: 1%</p>
<p>DEMAND MONITORING (Accuracies based on values ≤ 2 x CT and 125% VT)</p> <p><i>Measured values:</i> Current [A] 3φ Real power [kW] 3φ Reactive power [kvar] 3φ Apparent power [kVA]</p> <p><i>Measurement type:</i> Programmable block interval</p> <p><i>Programmable</i> <i>Time interval:</i> 5 ÷ 60 min; steps: 1min.</p> <p><i>Pickup Levels:</i> <u>Current</u> = 5 ÷ 5000 A; steps: 5 A <u>Real Power</u> = 10 ÷ 650000 kW; steps: 10 kW <u>Reactive Power</u> = 10 ÷ 650000 kvar; steps: 10 kvar <u>Apparent Power</u> = 10 ÷ 650000 kvar; steps: 10 kvar</p> <p><i>Accuracy:</i> ±3%</p>	<p>MEASURED PARAMETERS (Accuracies on 100% CT and 100% VT)</p> <p><i>RMS Current:</i> Phase A, B, C currents; Accuracy: ±1% of full scale.</p> <p><i>RMS Voltage:</i> A-N (A-B) / B-N (B-C) / C-N (C-A) Voltages <u>Accuracy:</u> ±1% F.S.</p> <p><i>Frequency:</i> Measuring of phase A-N or A-B <u>Scale:</u> 40.0 to 70.0 Hz; <u>Accuracy:</u> ±0.05 Hz</p> <p>Accuracies for 20% full scale<V<80% full scale , 10% CT<I<200%CT , PF > 0.5</p> <p><i>3f Real Power:</i> <u>Range:</u> -1000 to 1000 MW; <u>Accuracy:</u> ±2%full scale.</p> <p><i>3f reactive Power:</i> <u>Range:</u> -1000 to 1000 MVAR; <u>Accuracy:</u> ±2% full scale.</p> <p><i>3f Apparent Power:</i> <u>Range:</u> 0 to 1500 MVA; <u>Accuracy:</u> ±2% full scale.</p> <p><i>Power Factor:</i> <u>Range:</u> 0.00 Lag to 1.00 to 0.00 Lead; <u>Accuracy:</u> ±1%</p> <p><i>Watt/h:</i> Total, 1 hour. 0 ÷ 4200 GWh; <u>Accuracy:</u> ±3% full scale.</p> <p><i>Var/h:</i> Total, 1 hour. 0 ÷ 4200 GVarh; <u>Accuracy:</u> ±3% full scale.</p>
<p>EMISSIONS TESTS EN 55011 enclosure; EN 55011 AC mains</p>	<p>IMMUNITY TESTS EN 61000-4-6; EN 6100-4-4; ENV 50204; EN 61000-4-2; EN 61000-4-4; EN 61000-4-5; EN 61000-4-11.</p>

WIRING DIAGRAM

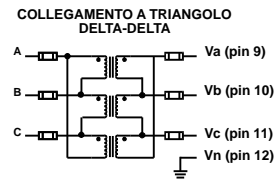
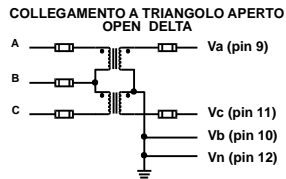
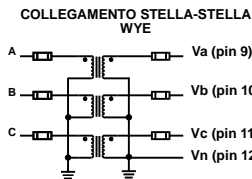
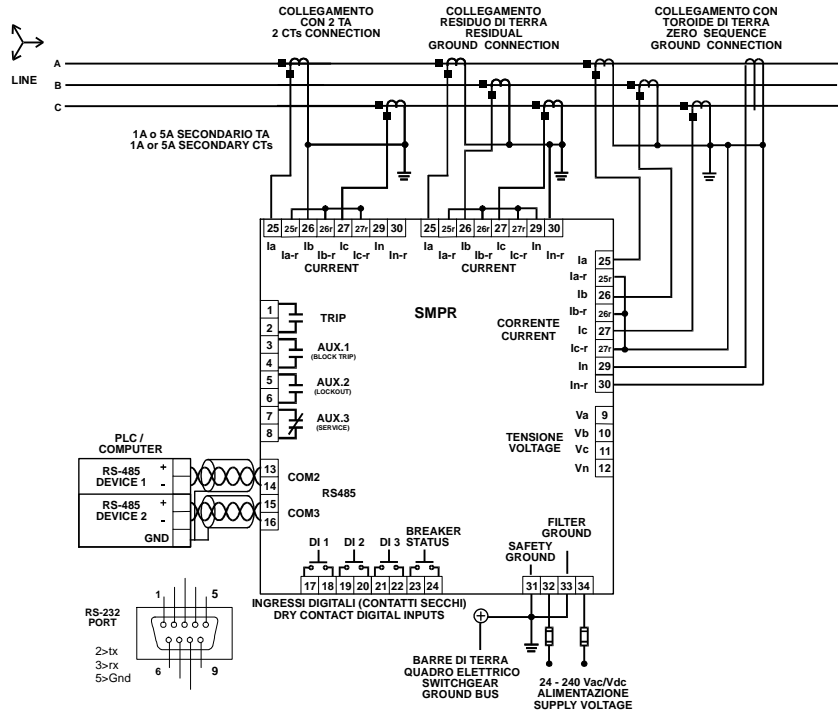

ORDER CODE

SMPR - X X X X

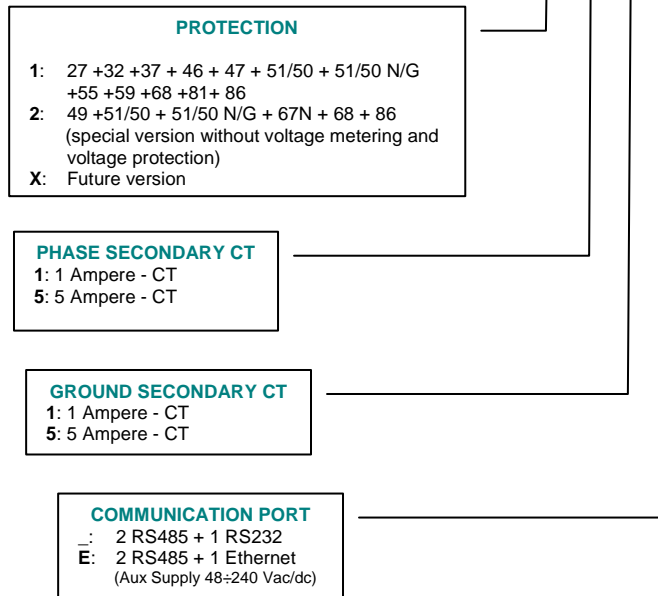

ORION ITALIA Srl
 Via G. Orsi 35, 29100 Piacenza [PC] –Italia
 Phone: + 39 0523591161 – Fax: + 39 0523593898 – www.orionitalia.com



Quality certified ISO 9001:2000